

Industrial Grinders & Random Orbit Sanders

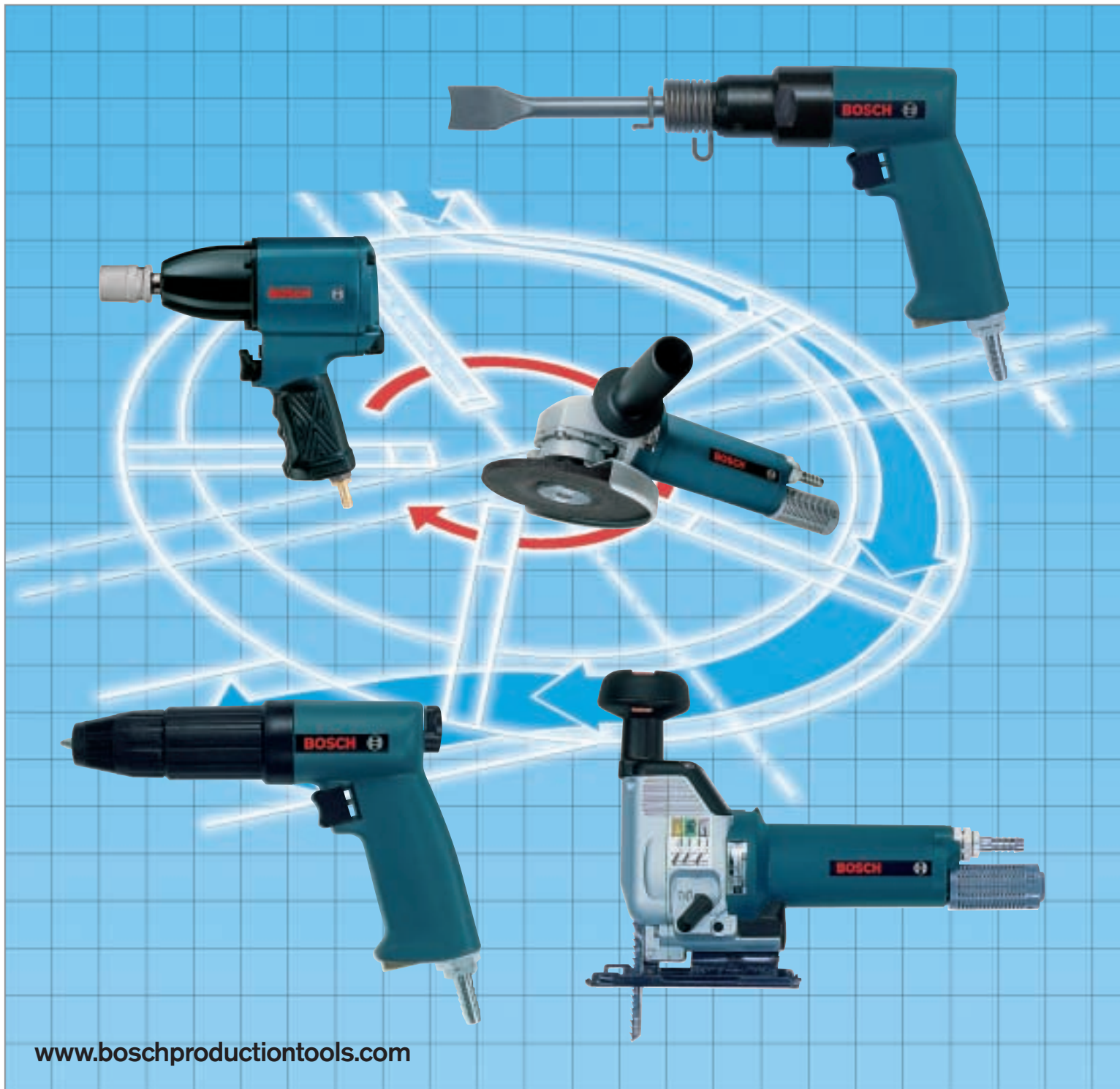

www.boschproductiontools.com



Grinders and Random Orbit Sanders

with 170, 320, 550 and 740 Watt Motors
(0.43 to 1 Hp)



Angle Grinder

- Polyamide housing reduces weight and provides operator comfort
- Grinder head is identical to Bosch electric models
- Powerful sleeve valve motor
- Speed control (on select models) for constant speed under high load
- Waste air expelled via handle

Random Orbit Sanders

- Speed regulated air motor
- Dust-protected riveted double cage bearing provides for long tool life
- Balanced eccentric action for low vibration operation
- Ergonomic, cold insulating plastic cover
- Integrated dust extraction system provides excellent extraction performance to remove waste material from work area
- Height adjustable extraction system allows for different sanding disc thicknesses
- Hook and loop fastening for Bosch sanding discs and accessories

Straight Grinder



320 Watt
0.43 Hp Motor

Straight Grinder



550 Watt
0.74 Hp Motor

Vertical Grinder

320 Watt
0.43 Hp Motor



Angle Grinder



550 Watt
0.74 Hp Motor

Random Orbit Sander

170 Watt
0.23 Hp Motor



Random Orbit Sander

170 Watt
0.23 Hp Motor



Tool part number	Recommended sanding/grinding accessory diameter (mm/inches)	No load speed (rpm)
0 607 260 100	40/1.6	21000
0 607 260 101	40/1.6	21000
0 607 252 103	40/1.6	21000
0 607 252 105	40/1.6	21000
0 607 360 100	75/3	19000
0 607 352 117	125/5	12000
0 607 352 109	125/5	12000
0 607 352 118	125/5	12000
0 607 352 113	125/5	12000
0 607 352 119	125/5	7000
0 607 352 112	125/5	7000
0 607 352 120	125/5	7000
0 607 352 114	125/5	7000
0 607 350 196	150/6	9000
0 607 350 197	150/6	9000

Power (watts/horsepower)	Air consumption under load (l/s)	Air consumption under load (cfm)	Weight (kg / lbs)	Toolholding fixture/spindle thread	Air inlet thread	Air hose inside diameter (inches)	Features	Included Accessories	Accessory Part numbers
320/0.43	8.5	18.0	0.6/1.3	6 mm collet	1/4" NPT	3/8"	Both models can use either available collet. Model ...100 includes 6 mm collet, model ...101 includes 1/4" collet.	6 mm Collet	3 600 224 011
320/0.43	8.5	18.0	0.6/1.3	1/4" collet	1/4" NPT	3/8"		1/4" Collet	3 600 224 021
								Collet nut 10 mm Open-end wrench 14 mm Open-end wrench Barbed hose nipple	1 603 349 010 1 907 950 504 1 907 950 508 2 603 386 002
550/0.74	12.5	26.5	1.1/2.4	6 mm collet	1/4" NPT	3/8"	Both models can use either available collet. Model ...103 includes 6 mm collet, model ...105 includes 1/4" collet.	6 mm Collet	2 608 570 079
550/0.74	12.5	26.5	1.1/2.4	1/4" collet	1/4" NPT	3/8"		1/4" Collet	2 608 570 085
							Both models feature locking switch with speed control	Collet nut 17 mm Open-end wrench Barbed hose nipple	3 603 342 001 1 907 950 510 2 603 386 002
320/0.43	8.5	18.0	0.7/1.5	3/8" - 24	1/4" NPT	3/8"		Protective guard Flange nut Open-end wrench Pin spanner wrench Barbed hose nipple Abrasive disc	3 605 510 007 3 603 342 004 2 607 950 511 1 609 310 098 2 603 386 002 3 608 600 000
550/0.74	14	29.7	1.3/2.9	5/8" - 11	1/4" NPT	3/8"	Locking switch w/speed control	Protective guard	1 605 510 155
550/0.74	14	29.7	1.3/2.9	M 14	1/4" NPT	3/8"	Locking switch w/speed control	Pin spanner wrench	1 607 950 052
550/0.74	14	29.7	1.3/2.9	5/8" - 11	1/4" NPT	3/8"	Dead man switch w/speed control	17 mm Open-end wrench	1 607 950 508
550/0.74	14	29.7	1.3/2.9	M 14	1/4" NPT	3/8"	Dead man switch w/speed control	Barbed hose nipple Silencer	2 603 386 002 3 607 000 073
550/0.74	14	29.7	1.3/2.9	5/8" - 11	1/4" NPT	3/8"	Locking switch	Auxiliary side handle	2 602 025 067
550/0.74	14	29.7	1.3/2.9	M 14	1/4" NPT	3/8"	Locking switch	Inner flange (M14 spindle)	1 603 340 015
550/0.74	14	29.7	1.3/2.9	5/8" - 11	1/4" NPT	3/8"	Dead man switch	Outer flange nut (M14)	2 605 703 023
550/0.74	14	29.7	1.3/2.9	M 14	1/4" NPT	3/8"	Dead man switch	Inner flange (5/8" - 11)	3 603 340 503
550/0.74	14	29.7	1.3/2.9	5/8" - 11	1/4" NPT	3/8"	Dead man switch	Outer flange nut (5/8" - 11)	3 603 340 501
170/0.23	10	21.2	1.4/3.1	5/16" - 24	1/4" NPT	3/8"	5 mm orbiting stroke Hook and loop backing pad accepts Bosch 6 inch sanding discs.	Dust extraction adapter Locking pin Hose clamp Barbed hose nipple Silencer	3 609 202 477 3 609 202 478 3 609 202 489 3 609 202 661 3 609 202 496
							Additional sander accessories are on page 20.		
170/0.23	10	21.2	1.5/3.3	5/16" - 24	1/4" NPT	3/8"	5 mm orbiting stroke Hook and loop backing pad accepts Bosch 6 inch sanding discs.	Locking pin Barbed hose nipple	3 609 202 478 3 609 202 661

All motor power & torque data in this catalog assumes an air pressure of 6.3 bar/91psi exists at the tool inlet. Correct air pressure and volume should be verified at inlet with the tool running at no-load speed.