

Industrial Air Drills & Rotary Hammer

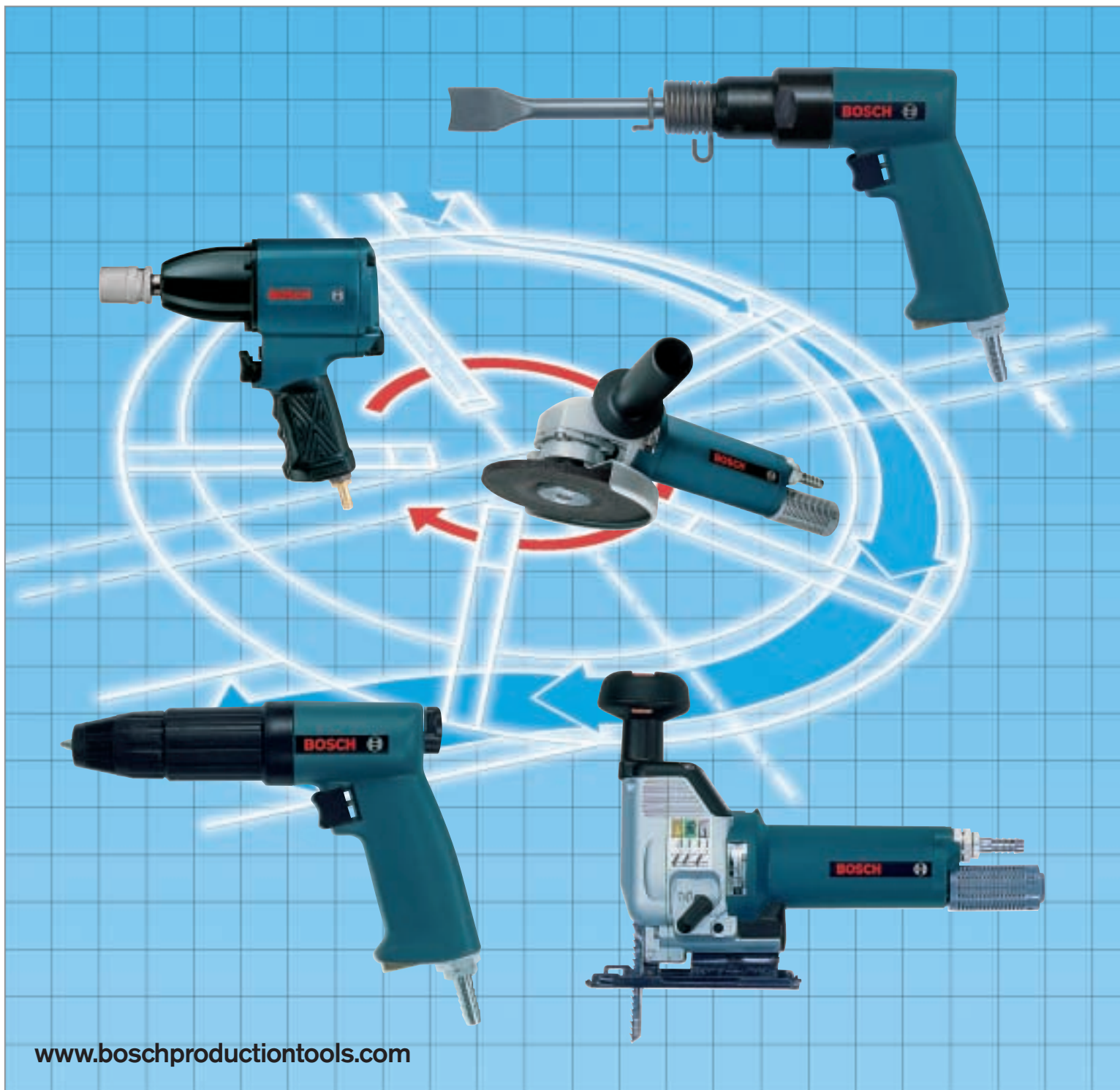

www.boschproductiontools.com



Industrial Air Drills and Rotary Hammer

with **320 Watt / 0.43 Hp Motors**
or **740 Watt / 1 Hp Motor**

Pistol Grip Drills

- Polyamide housing reduces weight and provides operator comfort
- Excellent performance/weight ratio
- Powerful air motor provides for long life and long run times without overheating
- Soft start trigger
- High quality planetary gearbox
- Waste air expelled via handle



Pistol Grip Drill



320 Watt
0.43 Hp Motor

Pistol Grip Drill



320 Watt
0.43 Hp Motor

Rotary Hammer



740 Watt
1 Hp Motor

Tool part number	Chuck type	Recommended Maximum drilling diameter in steel
0 607 160 501	3/8" Keyed	1/4"
0 607 160 502	3/8" Keyless	1/4"
0 607 160 511	3/8" Keyed	1/4"

Tool part number	Chuck type	Recommended Maximum drilling diameter in steel
0 607 160 504	3/8" Keyed	3/8"
0 607 160 505	3/8" Keyless	3/8"
0 607 160 509	3/8" Keyed	3/8"

Tool part number	Recommended Maximum drilling diameter	Full load speed (rpm)	Impact rate (rpm)
0 607 557 501	Concrete 3/4"	850	3900
	Steel 1/2"		
	Wood 1-1/8"		

No load speed (rpm)	Power (watts/horsepower)	Air consumption under load (l/s)	Air consumption under load (cfm)	Weight (kg / lbs.)	Drill spindle thread	Air inlet thread	Air hose inside diameter (inches)	Rotation (R = right, L = left)	Included Accessories	Accessory Part numbers
2800	320/0.43	8.5	18	0.6/1.3	3/8"-24	1/4" NPT	3/8"	R only	Keyed chuck	3 606 334 021
2800	320/0.43	8.5	18	0.7/1.5	3/8"-24	1/4" NPT	3/8"	R only	Keyless chuck	2 608 572 067
2200	220/0.3	8.5	18	0.7/1.5	3/8"-24	1/4" NPT	3/8"	R/L	Keyed chuck	3 606 334 021
									Barbed hose nipple	2 603 386 002
850	320/0.43	8.5	18	0.7/1.5	3/8"-24	1/4" NPT	3/8"	R only	Keyed chuck	3 606 334 021
850	320/0.43	8.5	18	0.8/1.8	3/8"-24	1/4" NPT	3/8"	R only	Keyless chuck	2 608 572 067
750	220/0.3	8.5	18	0.8/1.8	3/8"-24	1/4" NPT	3/8"	R/L	Keyed chuck	3 606 334 021
									Barbed hose nipple	2 603 386 002

Power (watts/horsepower)	Air consumption under load (l/s)	Air consumption under load (cfm)	Weight (kg / lbs.)	Chuck type	Connecting thread	Air hose inside diameter (inches)	Features	Included Accessories	Accessory Part numbers
740/1	16	33.9	2.7/5.9	SDS-plus with automatic lock	1/4" NPT	1/2"	Ideal for drilling in damp conditions. Hammer mechanism is identical to electric Bosch "Bulldog" model.	Auxiliary handle Depth stop Barbed hose nipple Plastic carrying case	2 602 025 070 1 613 001 008 3 603 458 008 1 615 438 136